

NON WOVENS

Brochure of

Mattresses

Logrotex
NON WOENS

NON-WOVENS FOR MATTRESSES

Most mattresses are made from non-woven technical fabrics. These materials have the characteristic of being hard-wearing while remaining soft to the touch. They are used in the manufacture of spring mattresses, foam mattresses, mesh bases and box springs, for internal linings, as a seam-stitching stabiliser or spring protector, or to finish the visible parts or outer protection layer of the mattress.

APPLICATIONS

These technical textiles can be used in different parts of the mattress where padding or protection against internal stress is required.

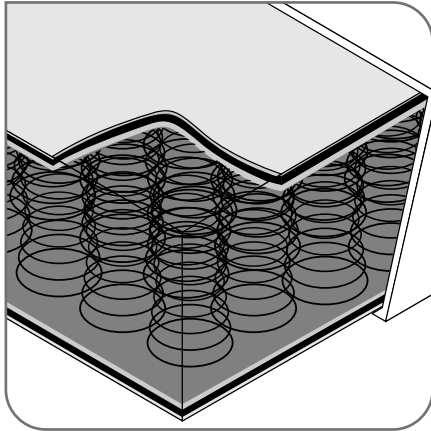

Felts for separation and load distribution

These afford the necessary protection to the upper layers of the mattress to prevent damage from spring

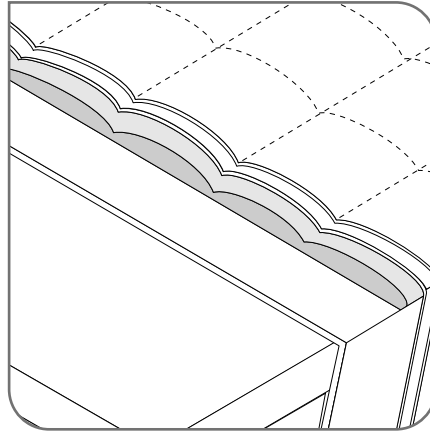

Padding

Natural and synthetic, for enhanced mattress comfort.

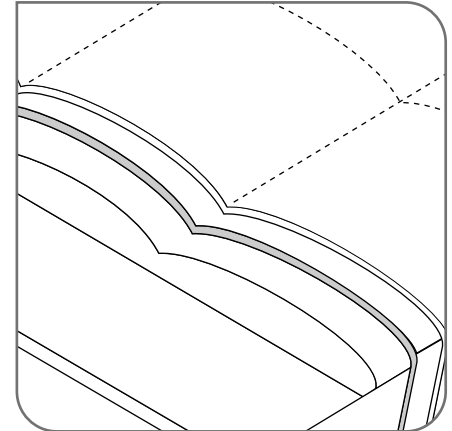

Felts with special treatments

Added value for more luxury products.

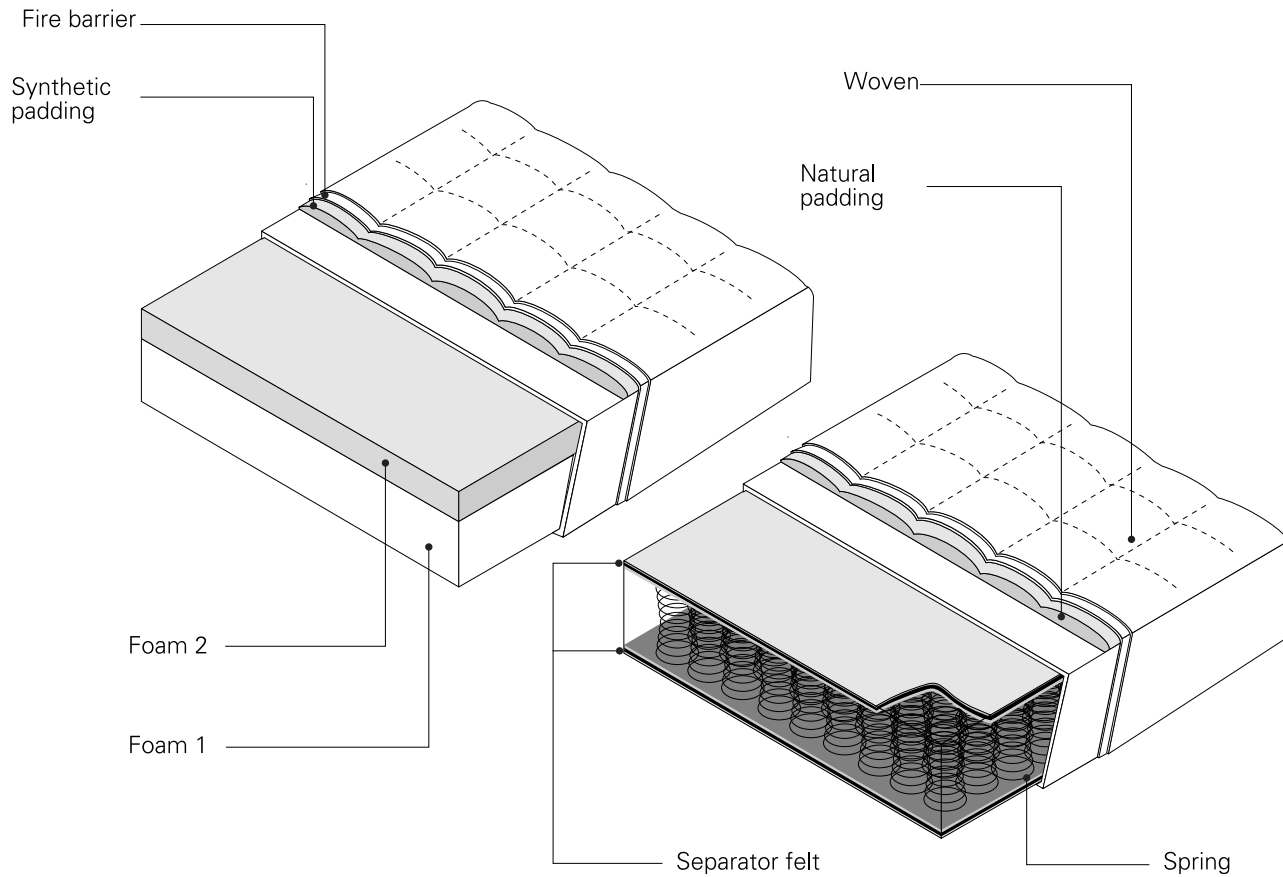

Standard composition of a mattress.

1. FELTS FOR SEPARATION AND LOAD DISTRIBUTION

Needle-punched, heat-set non-woven textiles made with or without backing (raffia, mesh, Vilene, etc.) from very strong and durable natural, artificial and recycled synthetic fibres. Very elastic, firm and comfortable, and highly adaptable to any type of spring. Highly versatile products that can be used in spring protection applications or as lumbar support.

This product range is manufactured in 200–2,500 g/m². Each product is manufactured to customer requirements, offering total flexibility.

400 range

Needle-punched felt made from **recycled synthetic, artificial and natural fibres**.

Used mainly as spring insulation.

400-R and 400-Franges

To increase the strength of the products in the 400 range, we have added backing products such as **raffia (R)** or **Vilene (F)**, which give added strength and greater consistency.



4075-RWO

These shock-absorbing felts are made of multicolour wool, which gives excellent absorption properties, hydrophobicity and thermal regulation. Therefore, providing a high degree of comfort to the mattress and volume.

Wool also has the quality of being natural fibre with enhanced fire resistance.

It also comes with a raffia backing for extra strength.

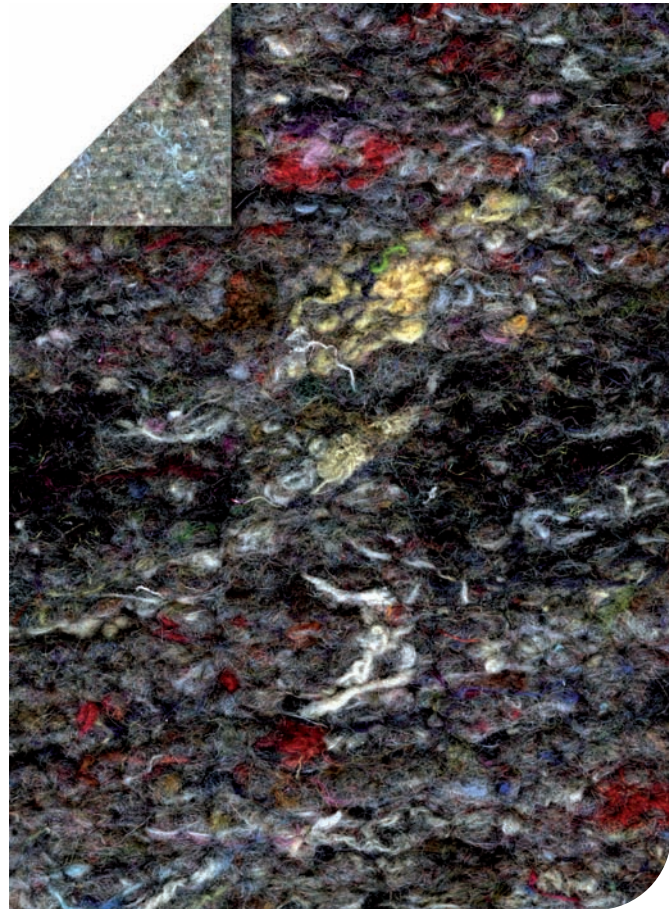

LOGROFOAM AND LOGROMOUSSE

These felt ranges follow the trends of the market in that they are manufactured from recycled fibres and foam.

The addition of shredded foam (Logrofoam) enhances the elasticity of the material while enhancing its ability to return to its original shape.

Logromousse is a felt range made from recycled mattress material. These materials give it elasticity, strength and the ability to return to its original shape.

Both ranges are used for spring insulation and as felt load separators.

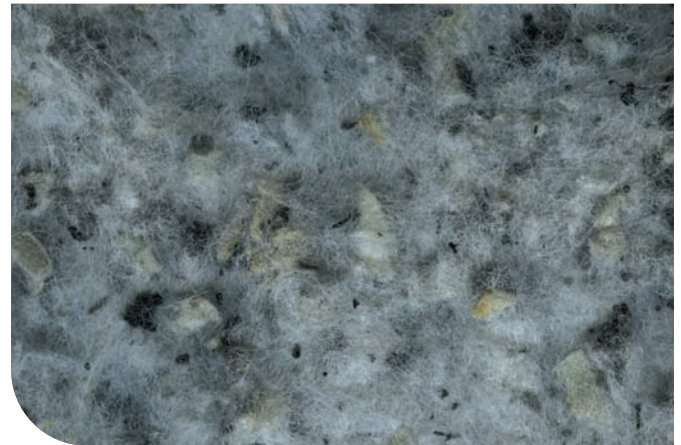

LOGROFOAM and LOGROMOUSSE characteristics

Weight (g/m ²)	from 300 to 5.000
Thickness (mm)	from 10 to 250
Packaging	plastic coated rolls or palletised sheets
Length (m)	up to 50 * Other sizes on request
Ancho (m)	up to 2.40

ISOLGREEN® JUTE

isolgreen

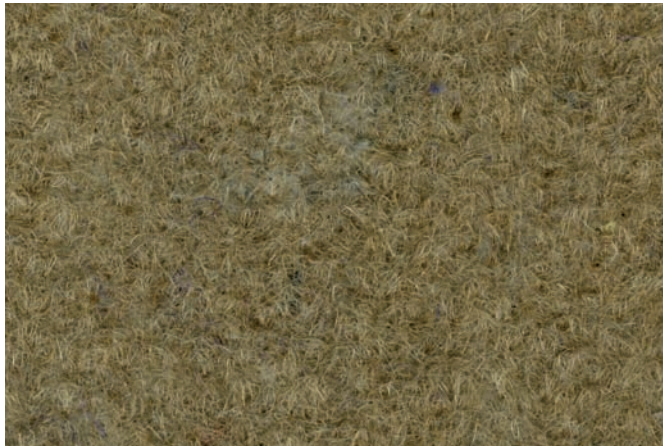

JUTE (JU)

Very stiff, needle-punched **jute** felt with insulating and cushioning properties for springs. It is **made with or without a raffia**, mesh or light nonwovens backing, which adds strength and durability.

Heat-set jute composed of natural jute fibres and fusible fibres. Besides its value as a green product, **jute** fibre confers strength and durability to the product. It is rich in lignin, making it the ideal reinforcement material.

As a **biodegradable** product, it is transformed into a harmless material during its life cycle.

ISOLGREEN® JUTE characteristics

Weight (g/m ²)	from 300 to 5.000
Thickness (mm)	from 5 to 250
Packaging	plastic coated rolls or palletised sheets
Length (m)	up to 50 * Other sizes on request
Width (m)	up to 2.40

JUTE FELT characteristics

Weight (g/m ²)	from 400 to 2.000
Thickness (mm)	from 3 to 10
Packaging	plastic coated rolls or palletised sheets
Length (m)	up to 100 * Other sizes on request
Width (m)	up to 4.10



2. NATURAL PADDING ISOLGREEN®

Logrotex works with a wide variety of **natural fibres**, allowing us to offer a wide range of **versatile products** adapted to the tastes of individual customers.

These fibres include wool, jute, cotton, hemp, flax, coconut and sisal.



FLAX (FL)

Product manufactured with soft, **natural flax fibres**. Flax fibre is **strong, flexible and very hard-wearing**, and it is an environmentally-friendly material since natural fibres are used to produce it.

With its high moisture-absorption capacity, it is pleasantly **cool** to the touch, offering a **soft** finish and attractive texture.

SILK-WOOL

isolgreen

For those seeking **natural and environmentally-friendly** products, we offer a line of fine materials: silk, wool and flax. This material is **flexible, hard-wearing and soft to the touch**. The combination of these fibres provides a **cool**, pleasant sensation.

Natural luxury with no harmful substances.

SILK-WOOL characteristics

Weight (g/m ²)	from 150 to 2.000	
Thickness (mm)	from 1.5 to 10	
Packaging	plastic coated rolls	
Length (m)	up to 100	* Other sizes on request
Width (m)	up to 3.30	

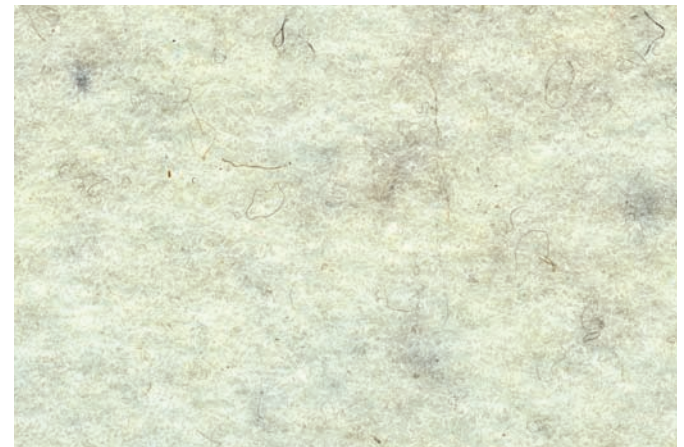

ISOLGREEN® COTTON (CO) **isolgreen**

Cotton is rich in cellulose, which gives this fibre its unique durability, abrasion resistance and moisture absorption properties.

Warm and soft to the touch, this material is more elastic and resistant to crushing after heat-forming. The product consists of **fluffy** cotton lap for padding that wicks away water and offers a **cool sensation**.

NEEDLE-PUNCHED WOOL (WO)



NEEDLE-PUNCHED COTTON (CO)



ISOLGREEN® COTTON characteristics	
Weight (g/m ²)	from 300 to 5.000
Thickness (mm)	from 5 to 250
Packaging	plastic coated rolls or palletised sheets
Length (m)	up to 50 * Other sizes on request
Width (m)	up to 2.40





ISOLGREEN® WOOL (WO)

isolgreen

The **wool** range is manufactured from wool and heat-bonded fibres, creating the perfect product for fluffy padding.

The bonding of the fibres with heat gives the padding excellent **flexibility**.

Our wool is pre-treated with components to give it flame-retardant, anti-mite and fungicide properties.

These **lightweight** products have optimal insulation properties, keeping the body and the bed at the right temperature.

This product range is also available in white wool.

Due to its excellent temperature insulation properties, it is also marketed as thermal and acoustic insulation under the name IsolGreen.

ISOLGREEN® WOOL characteristics

Weight (g/m ²)	from 300 to 5.000
Thickness (mm)	from 5 to 250
Packaging	plastic coated rolls or palletised sheets
Length (m)	up to 50 * Other sizes on request
Width (m)	up to 2.40

ISOLGREEN® SICO

isolgreen

ISOLGREEN® SICO is a heat-set product composed of sisal, coconut and fusible fibres.

Sisal fibre is more lustrous, white, thin and hard-wearing than the fibre of any other agave.

The typical moisture content of this fibre is 10–12%.

The combination of sisal and coconut fibres makes for a **very strong and rigid** product.



ISOLGREEN® COCO

ISOLGREEN® COCO is a heat-set natural product made of fusible coconut fibres.

Coconut fibre belongs to the hard-fibre family and its main components are cellulose and lignin, which give it **rigidity and strength**.

It is an **odourless** fibre that is totally moisture-resistant and, due to its woody structure, it is not attacked by insects.



3. SYNTHETIC PADDING ISOLGREEN®

There are plenty of synthetic fibres available on the market that we can use to make our synthetic padding. We work with all types of fibre, both virgin and recycled.

These materials are very spongy, which enhances their comfort, and they have an excellent ability to return to their original shape.

MULTI-COLOUR RECYCLED **isolgreen**

L-300 is a line of products made with **heat-bonded recycled multi-coloured fibres**.

The use of heat-bonded fibres affords greater sponginess, elasticity and comfort to our products.

L-300 RANGE characteristics

Weight (g/m ²)	from 300 to 3,000
Thickness (mm)	from 5 to 250
Packaging	plastic coated rolls or palletised sheets
Length (m)	up to 50 * Other sizes on request
Width (m)	up to 2.40





ISOLGREEN® POLYESTER (PET)

Our synthetic ISOLGREEN® POLYESTER lap has excellent **separation, strengthening and padding** properties suited to its various mattress applications.

Manufactured in 100% polyester substandard virgin fibre, it is **durable and hard-wearing**.

Our non-woven fabrics are heat-set, which adds strength and makes for a **spongier** finish.

ISOLGREEN® ANTI-BACTERIAL

Like our ISOLGREEN® POLYESTER range, ISOLGREEN® ANTI-BACTERIAL is an excellent **padding** product.

The fibre is treated with biocides incorporated in the extrusion process. This ensures the high wash resistance, durability and stability of its **antibacterial properties** over time.

The product is strengthened by heat-bonding, giving it a rigid, unalterable and very spongy form.

ISOLGREEN® PET & ANTI-BACTERIAL characteristics

Weight (g/m ²)	from 300 to 5.000
Thickness (mm)	from 5 to 250
Packaging	plastic coated rolls or palletised sheets
Length (m)	up to 50 * Other sizes on request
Width (m)	up to 2.40



4. FELTS WITH SPECIAL TREATMENTS

Customers often require mattresses with added value and special properties. We add different properties to our products either by using processed fibres or by processing after manufacture.

WATER-REPELLENT

PET-WATER REPELLENT felt is manufactured with 100% polyester fibres.

The water-repellent finish added by Logrotex makes our product resistant to water.

The final finish applied to PET-WATER REPELLENT also gives added stiffness to the product.

The water-repellent characteristic of PET-WATER REPELLENT is checked internally by our laboratory from the very start of its manufacture.

Our Quality Assurance Department validates the appearance of the "pearl effect" and **non-absorption** of liquids in the end product.

PET-WATER REPELLENT characteristics

Weight (g/m ²)	400	* Other sizes on request
Thickness (mm)	2	
Packaging	plastic coated rolls	
Length (m)	100	* Other sizes on request
Width (m)	up to 2,20	





FIRE BARRIER

LTX-250-FR is the end result of a year of researching and developing the product in our R&D&i department.

Our flame-retardant product meets American Standard 16 CFR Part 16331 of the United States Consumer Product Safety Commission, which sets down the parameters for the flammability of mattress sets.

The flame-retardant properties of our product are tested and validated by our Quality Department from the very start of their manufacture.

Our laboratory performs continuous internal open-flame ignition tests during manufacture to guarantee the effectiveness of **LTX-250-FR**.

FIRE BARRIER characteristics

Weight (g/m ²)	250	* Other sizes on request
Thickness (mm)	2.5	
Packaging	plastic coated rolls	
Length (m)	100	* Other sizes on request
Width (m)	up to 4	

FLAME-RETARDANT COTTON (FR CO)

Flame-retardant cotton felt spacers and load distributors, manufactured from **natural and synthetic fibres** with a heat-fused finish.

Spring shock-absorbing, made of thermobonding fibres, making this a very strong and adaptable product.

Multi-coloured product with a rigid and unalterable form.

FLAME-RETARDANT COTTON (FR CO) characteristics

Weight (g/m ²)	from 300 to 5.000	
Thickness (mm)	from 10 to 100	
Packaging	plastic coated rolls or palletised sheets	
Length (m)	up to 50	* Other sizes on request
Width (m)	up to 2.40	



SANITIZED® ANTIBACTERIAL

With Sanitized®, the textile fibres of our materials are immune to bacterial attack, which prevents odours, putrefaction and mould.

It gives our materials continuous additional protection from dust mites, fungi, mould and bacteria.

Sanitized® prevents the appearance of a large number of microorganisms, ensuring the complete and lasting hygiene of our mattresses. It prevents a high concentration of reactive allergens from coming into contact with the skin, ensuring that the surface remains in perfect condition.

The fabric is protected, preventing early wear of the mattress.

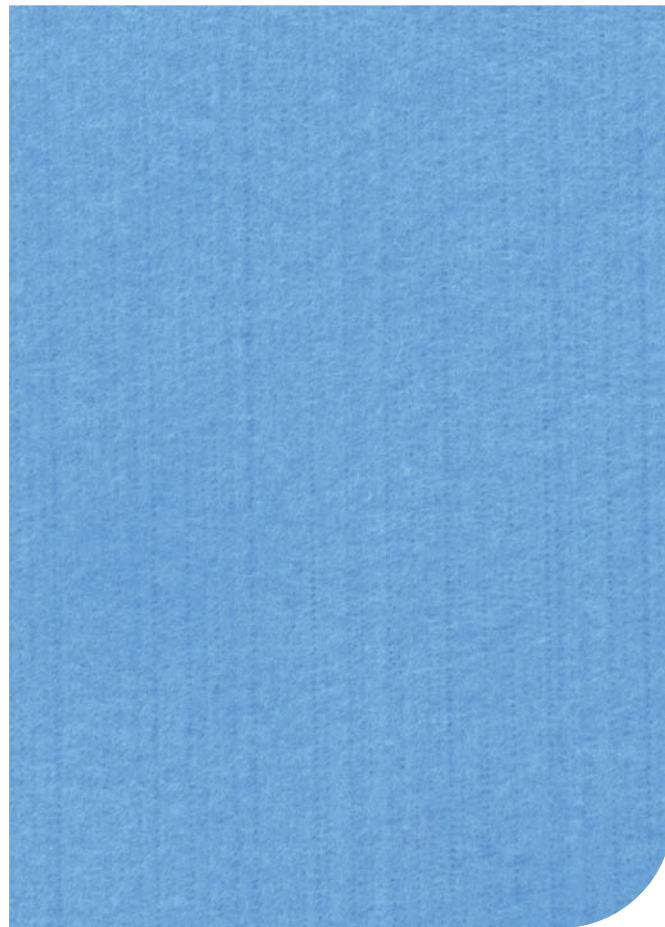

NON WOVENS

Logrotex
NON WOVENS

C. Alberite, 11 - 17
26006 · Logroño · Spain

T.: + 34 941 211 211

F.: + 34 941 210 347

www.logrotex.com

logrotex@logrotex.com



ER-0222/2003

